

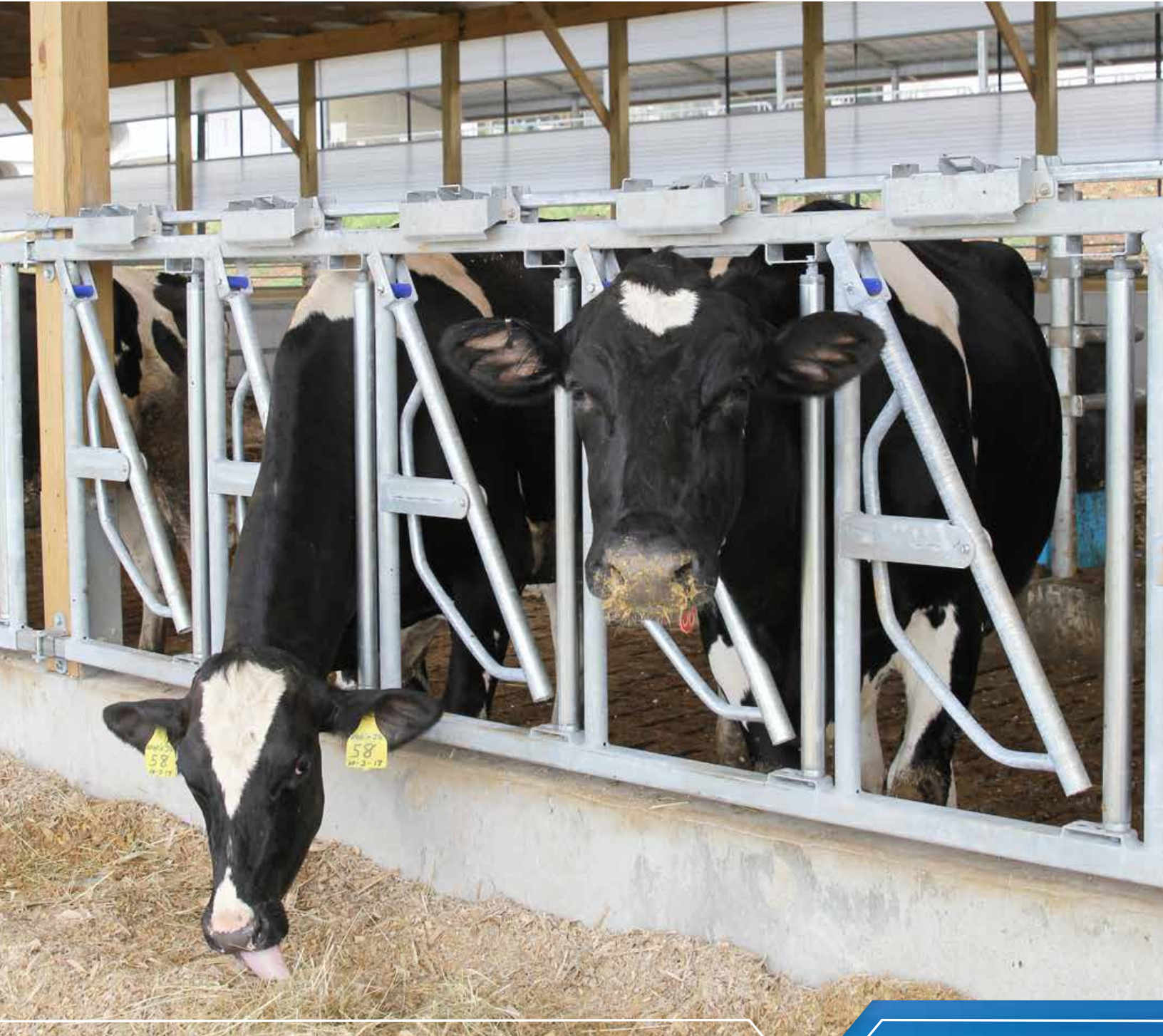

# Feedbunk Management



Greater Cow Health, Efficiency,  
and Productivity at the Feed Bunk





# Table of Contents

- Sturdy Built Feeding Systems . . . . . 3
- Sturdy Built Headlock Specifications . . 4
- Signature Series Headlocks . . . . . 5-7
- Paragon Series Headlocks . . . . . 8-9
- Paragon XL Series Headlocks . . . 10-11
- In-Stock Headlocks . . . . . 12
- Mounting Hardware . . . . . 12
- Feed Rail Systems . . . . . 13
- Slantbar Feed-Through Fencing. . 14-15

## Sturdy Built Headlocks for Any Application!



Maternity Pen featuring Gates, Fencing and Paragon Series Headlocks



Headlocks In A Gate - Paragon Series



Calf Headlock Gate - for vaccinating, dehorning and vet care







## *Feeding for Greater Cow Health, Efficiency & Productivity*

### **Headlocks**

Headlocks are the popular choice for restraining groups of animals for examination & treatment at the feedbunk. Individual animals or entire rows can be locked and released.



*See Pages 4-12*

### **Slantbar**

Slantbar feed-through panels and gates with diagonal divider bars require the animals to tilt their heads when entering and exiting, resulting in longer feeding periods with less backouts and minimal wasted feed.



*See Page 14-15*

### **Feed Rail**

Feed Rail is an economical restraint system for the feedbunk where individual head lock-ups or slantbar feed-through panels are not required.



*See Page 13*





# Headlock Specifications

- Galvanized steel, square tubular frame construction  
1.75" square x 12 gauge frame for calf locks, 2" square x 12 gauge frame for cow & heifer locks
- Locking mechanism remains motionless in unlocked position, reducing wear and noise
- Automatic down cow release in unlocked position
- Bolt-together install requires no welding on site



**Signature Series**

Signature Series Headlocks feature a wide-open design, quiet operation and durable construction with automatic down cow release.

Pages 5-7



IN STOCK

**Paragon Series**

Paragon Series Headlocks have been engineered for production efficiency and also offer the same innovative features of the "Original" Signature series.

Pages 8-9



**XL**  
FOR XL COWS

NEW

**Paragon XL Series**

Paragon XL Series Headlocks feature an exclusive extra-wide design, produced especially for large-cow herds where size adjustment is not necessary.

Pages 10-11

	Adjustable Calf	Adjustable Heifer	Adjustable Cow	Non Adjustable Cow	
	Signature/Paragon	Signature/Paragon	Signature/Paragon	Signature/Paragon	Paragon XL
Overall Frame Height	30"	40"	40"	40"	40"
Entry Width	11"	13 1/2"	16 3/4"	16 3/4"	19 3/4"
Closed Width	6" or 4 1/2"	8", 7" or 5 3/4"	8", 7" or 5 3/4"	8"	8"
Required Opening Distance	17 1/2" per lock (approximate)	20 3/4" per lock (approximate)	24" per lock (approximate)	24" per lock (approximate)	24" per lock (approximate)



# Signature Series

Durable Construction  
Wide-Open Design  
Quiet Operation



Convenient Individual Cow Lockup

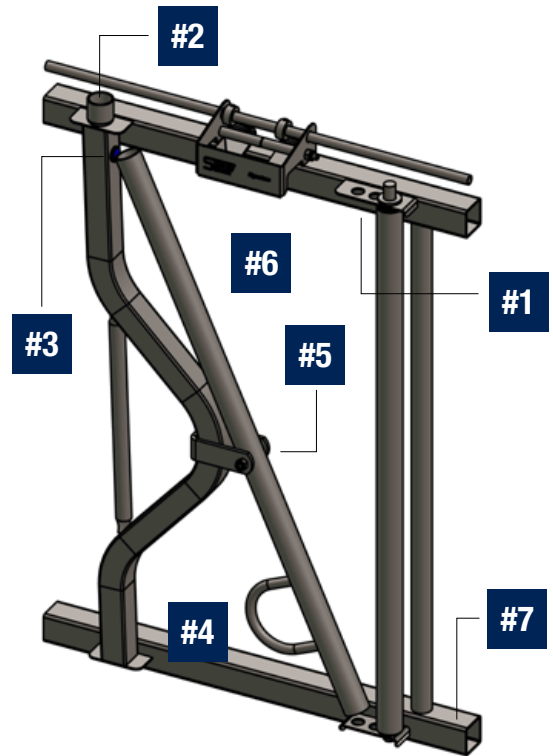

- 1 - Adjustable width for size flexibility
- 2 - Individual lockup for operator convenience
- 3 - Poly cushioned for quieter operation
- 4 - Automatic down cow release for animal safety
- 5 - **Extruded bushing** at swing bar pivot
- 6 - Wide-open design for easy entry
- 7 - Square tubing frame construction for strength

- Control latch is clamped on and can easily be moved



**Clamp-on Control Latch**  
for convenient positioning



# Signature Series Headlocks

*A Sturdy Built Original!*



Calf Size

Heifer Size



A good dairyman knows that he must interact regularly with his dairy herd, whether for inspection, treatment, or breeding. Sturdy Built's headlocks have been designed to effectively secure the cows you need to work with, while providing a safe and comfortable feeding environment. Manufactured of galvanized steel, your investment in Sturdy Built headlocks will pay back quickly and serve you well for many years.







**Headlock in a Gate**



**Heifer Size**

Choose a standard length or provide us your opening sizes and we'll build to fit into your existing openings with no on-site modifications needed!



**Cow Size**



# Paragon Series



Engineered for  
Production Efficiency

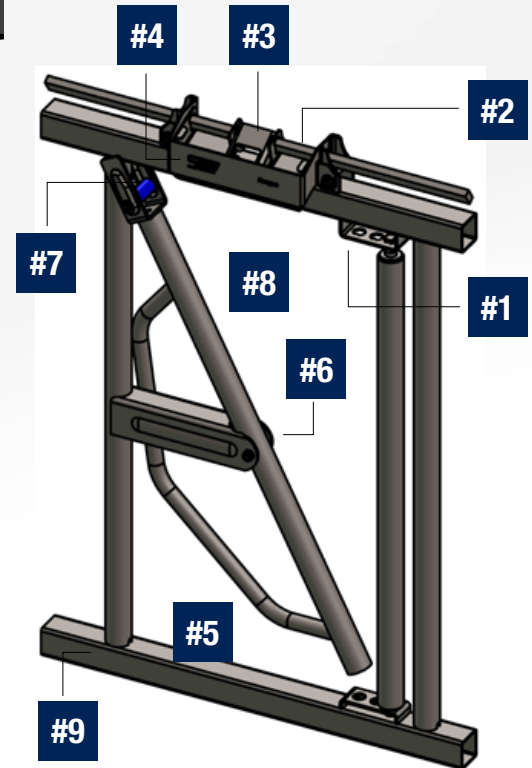

- 1 - Adjustable width for size flexibility
- 2 - Locking trippers have finger grips for quick release
- 3 - Self-contained individual cow lockup mounted on control rod
- 4 - Bolt-on tripper guard
- 5 - Automatic down cow release for animal safety
- 6 - **Extruded bushing** at swing bar pivot
- 7 - Poly cushioned for quieter operation
- 8 - Wide open design for easy entry
- 9 - Square tubing frame construction for strength

- Control latch is clamped on and can easily be moved



**Clamp-on Control Latch**  
for convenient positioning





Cow Size

Our galvanized headlocks are built to withstand inclement weather outdoors as well as the challenge of inside environments. Outfit your facilities with the assurance of proven, durable feeding equipment.



Heifer Size



Calf Size



High  
Made in USA  
Quality



NEW

# Paragon XL Series



Extra-Wide Entry  
for XL Cows



- 1 - Exclusive Extra-wide design
- 2 - Locking trippers have finger grips for quick release
- 3 - (Optional) self-contained individual cow lockup add-on
- 4 - Bolt-on tripper guard
- 5 - Automatic down cow release for animal safety
- 6 - **Extruded bushing** at swing bar pivot
- 7 - Poly cushioned for quieter operation
- 8 - Square tubing frame construction for strength
- Control latch is clamp-on for convenient positioning





Self-Contained Individual  
Cow Lockup (Optional)



Control Latch is clamp-on  
for convenient positioning



# Paragon XL Series

Ultra Heavy-Duty, Extra Wide Design for Large-Cow Herds



High  
Made in USA  
Quality



# Need **Sturdy Built** Headlocks NOW?



*Available in Adjustable and Non-Adjustable*

## WE STOCK

*Paragon Series Headlocks!*



### COW SIZE

- 6' (3 head) • 10' (5 head)
- 8' (4 head) • 12' (6 head)

### HEIFER SIZE

- 8' 6" (5 head) • 10' (6 head)
- 12' (7 head)

## Headlock Mounting Hardware Options

Hot-Dipped Galvanized Mounting Hardware for Sturdy Built Headlocks.  
In stock for between posts, face mount and tip-out configurations.

### Headlock Curb Support Bracket

Recommended for sections over 12' in length

#### Wood Post Mount



**NEW!**

#### Wide Tab Bolt-on Face Mount Clamp

*Choice of Face mount or Tipout*



#### Bolt-on Insert

*Universal for Between and Tipout Mount*

#### Steel Post (Clamp)



**NEW!**

#### Wide Tab Clamp-on Face Mount Clamp

*Choice of Facemount or Tipout*



#### Clamp-on Round Insert

*Universal for Between and Tipout Mount*

#### Steel Post (Weld)



**NEW!**

#### Wide Tab Weld-on Face Mount Clamp

*Choice of Facemount or Tipout*



#### Weld-on Insert

*Universal for Between and Tipout Mount*





# Galvanized Feed Rail Systems



Clamp-on  
for Steel Posts



Weld-on for  
Steel Posts



Bolt-on for  
Wood Posts



The Feed Rail Feeding System is a well known and economical approach where individual head lock-ups or slantbar feed-through panels are not preferred.

Sturdy Built's Feed Rail System is constructed of high tensile galvanized tubing and heavy wall galvanized steel posts. Hot-dipped galvanized mounting brackets are available for wood or steel posts.

Feed Rail Divider Stalls can also be placed to give each cow more freedom when eating, increasing intake. Eliminate pressure from boss cows!



## Adjustable Feed Rail Brackets

Added height flexibility for changing animal ages and sizes. Featuring simple adjustment. Mount to building support posts.

## Standard Feed Rail Specifications

- 2.875" OD heavy wall galvanized posts
- 2.375" OD x 12 gauge high tensile galvanized tubing for feed rail
- Hot-dipped galvanized mounting hardware



## Feed Rail with Divider Loops

Allows cows to eat without pressure from boss cows



# Slant Bar Feed-Through Fencing

*for Calves, Heifers and Cows*



University trials have shown that slant bar feeding encourages cows to keep their heads in position at the feed bunk, reducing feed waste significantly. You can easily observe this on your own farm.

Sturdy Built's durable slant bar feed through panels and gates are constructed with square tubing frames for maximized strength. Bar spacing is adjusted for the size and age of the animals being fed. All mounting hardware is hot-dipped galvanized after welding.



**Detachable Stainless  
or Galvanized Feed Troughs**  
fasten easily on slant bar gates & panels



Our Slant Bar Panels and Gates are a practical option for feeding areas where individual headlocks are not preferred. These panels and gates are also built to fit into your existing openings.





## Slant Bar Specifications

- Square tubular frame constructed of durable 1.75" square x 12 gauge galvanized tubing
- Divider bars are 1.315" galvanized round tubing
- Standard divider bar spacings are 9" for calves, 11" for heifers, and 13" for cows
- Hot-dipped galvanized mounting hardware available for between posts, face mount and tip-out configurations



**Straight Bar Panels and Gates** - Ideal for Horses

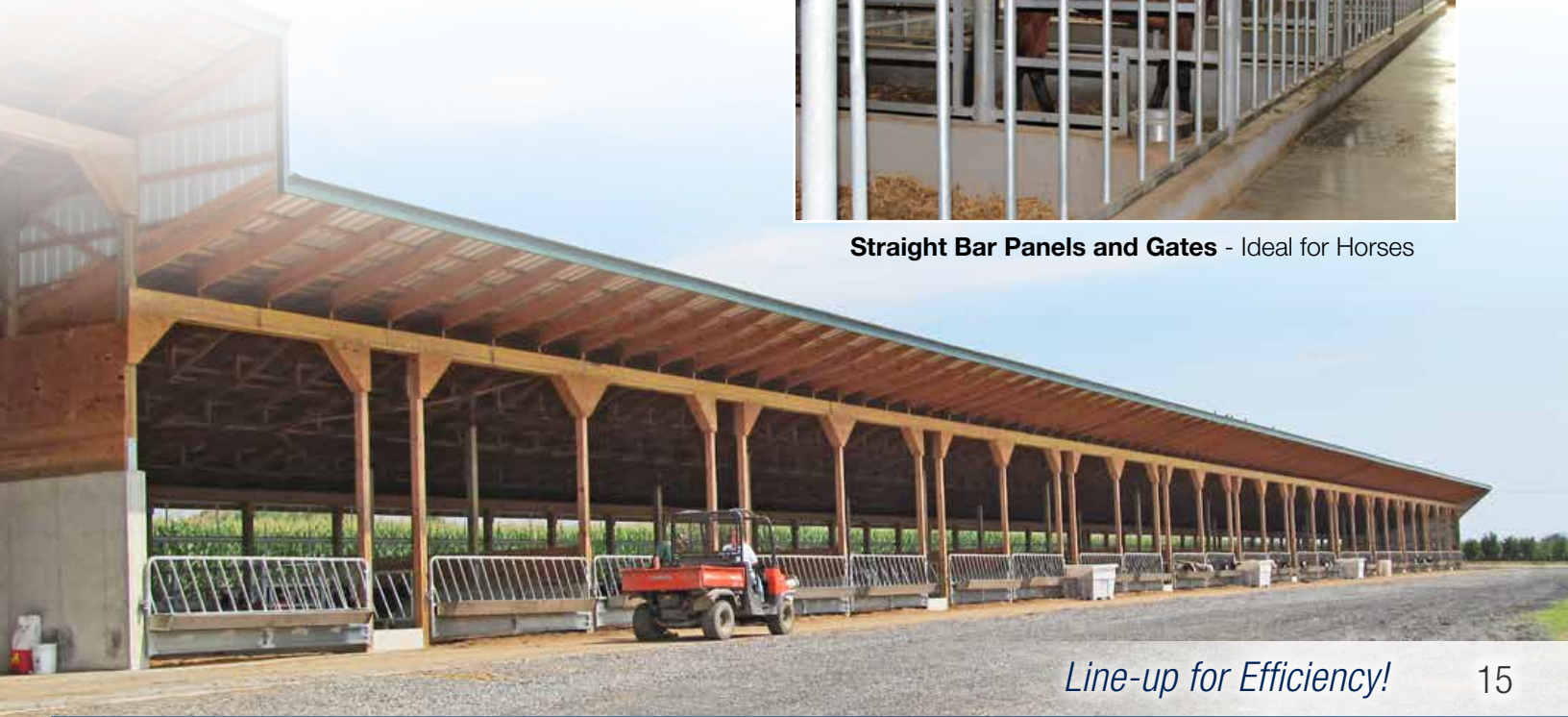



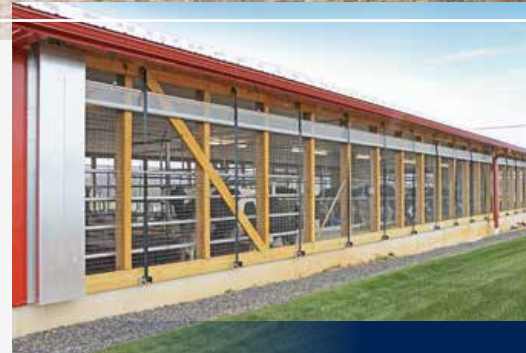

See all of our Equipment Guides for more Sturdy Built Galvanized Dairy Solutions!

**Calf Nurseries • Curtain Systems • Free Stalls • Gates & Fencing • Headgates & Chutes • Feedbunk Management • Robotics • Tie Stalls**



260 S. Muddy Creek Road, Denver, PA 17517  
Toll Free: 866-543-5116 • Phone: 717-335-3030  
Fax: 717-335-3020 • sales@sturdybuiltmfg.net

Dealer: